

Important! Must be read prior to installation

Recommended Minimum & Maximum Bolt Torques Machined Bolts & Cold Roll Steel Studs

Nominal Size	Stud or Bolt Size	Min. Torque Lubed (ft/lb)	Max. Torque Lubed (ft/lb)
2" ~ 4"	5/8" - 11 UNC	32	38
6" & 8"	3/4" - 10 UNC	56	65
10" & 12"	7/8" - 9 UNC	54	63
14" & 16"	1" - 8 UNC	82	95
18" & 20"	1 1/8" - 7 UNC	117	135
24" & 30"	1 1/4" - 7 UNC	165	190
36" ~ 48"	1 1/2" - 6 UNC	282	325

* For alloy steel (B-7) bolts call Trueline

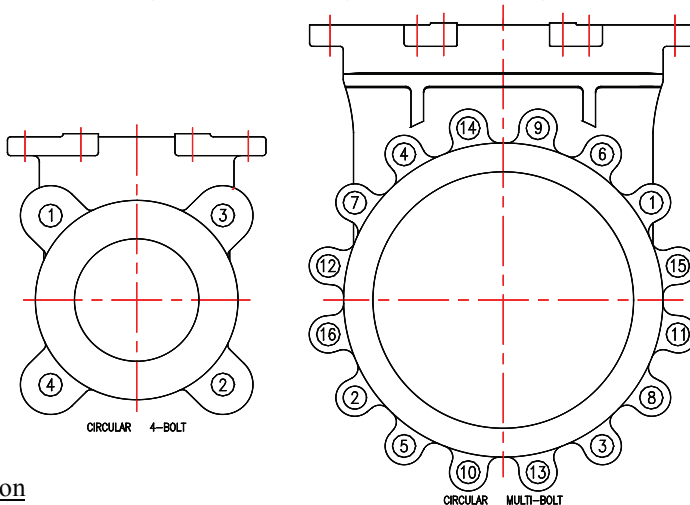

Installation

- Tighten bolts or studs to compress the flange uniformly. This means going from side to side around the flange according to proper bolting patterns (refer to above diagram).
- Use a torque wrench and well lubricated fasteners with flat washers to ensure correct initial loading.
- All bolts should be tightened in one-third increments, according to proper bolting patterns (refer to above diagram).

For additional information contact Trueline @
1-800-667-4819 or your local distributor.